

Property of Lite-On Only

Features

- * Package in 12mm tape on 7" diameter reels.
- * Compatible with automatic placement equipment.
- * Compatible with infrared and vapor phase reflow solder process.
- * EIA STD package.
- * I.C. compatible.
- * Meet green product and Pb-free(According to RoHS)

Package Dimensions

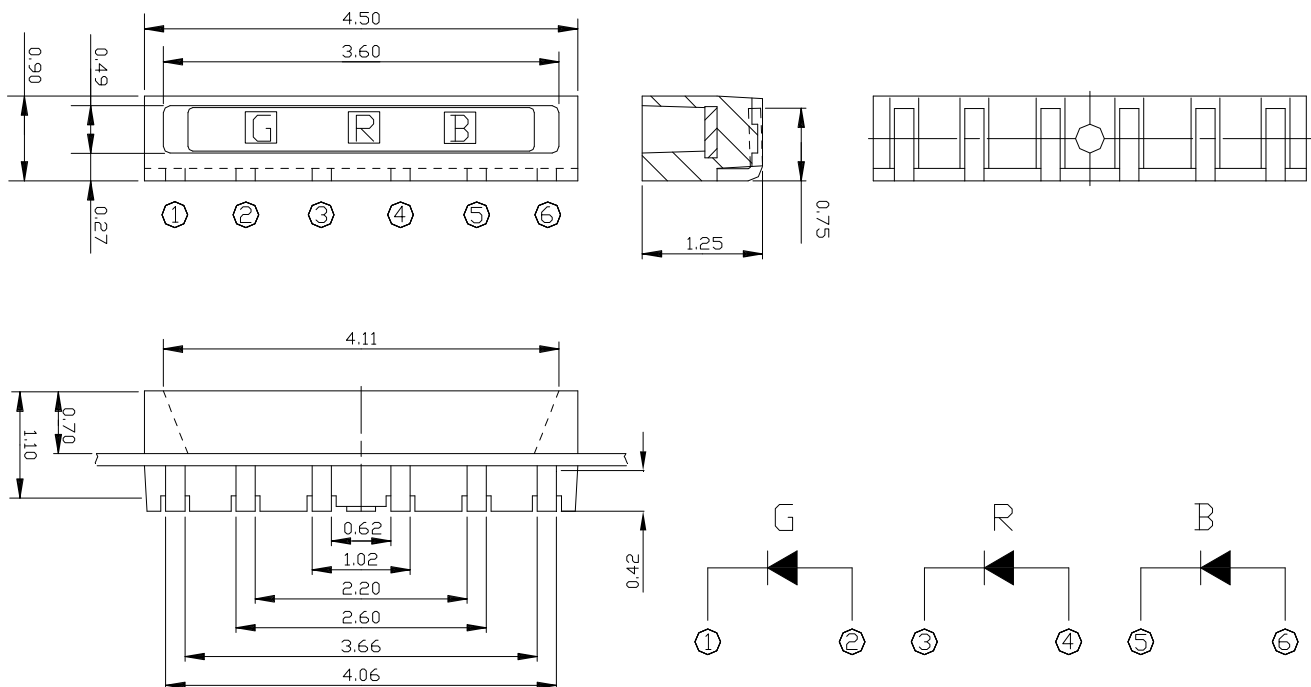

Part No.	Lens Color	Source Color
LTW-008RGB-L	White Diffused	InGaN Blue
		InGaN Green
		AlInGaP Red

Notes:

1. All dimensions are in millimeters (inches).
2. Tolerance is ± 0.1 mm (.004") unless otherwise noted.

Property of Lite-On Only

Absolute Maximum Ratings at Ta=25 °C

Parameter	Symbol	Rating			Unit
		R	G	B	
Power Dissipation	P_o	75	120	120	mW
Peak Forward Current ¹	I_{FP}	100	100	100	mA
Continuous Forward Current	I_F	30	30	30	mA
Reverse Voltage	V_R	5			V
Operating Temperature Range	T_{opr}	-40 ~ +85			°C
Storage Temperature Range	T_{stg}	-40 ~ +100			°C
Soldering Condition	T_{sol}	260°C For 10 Seconds			

Note:

1. Reverse Voltage can't be continued operating.
2. 1/10 Duty Cycle, 0.1ms Pulse Width.

Suggestion IR Reflow Profile For Pb Free Process :

IR-Reflow Soldering Profile for lead free soldering (Acc. to J-STD-020D)

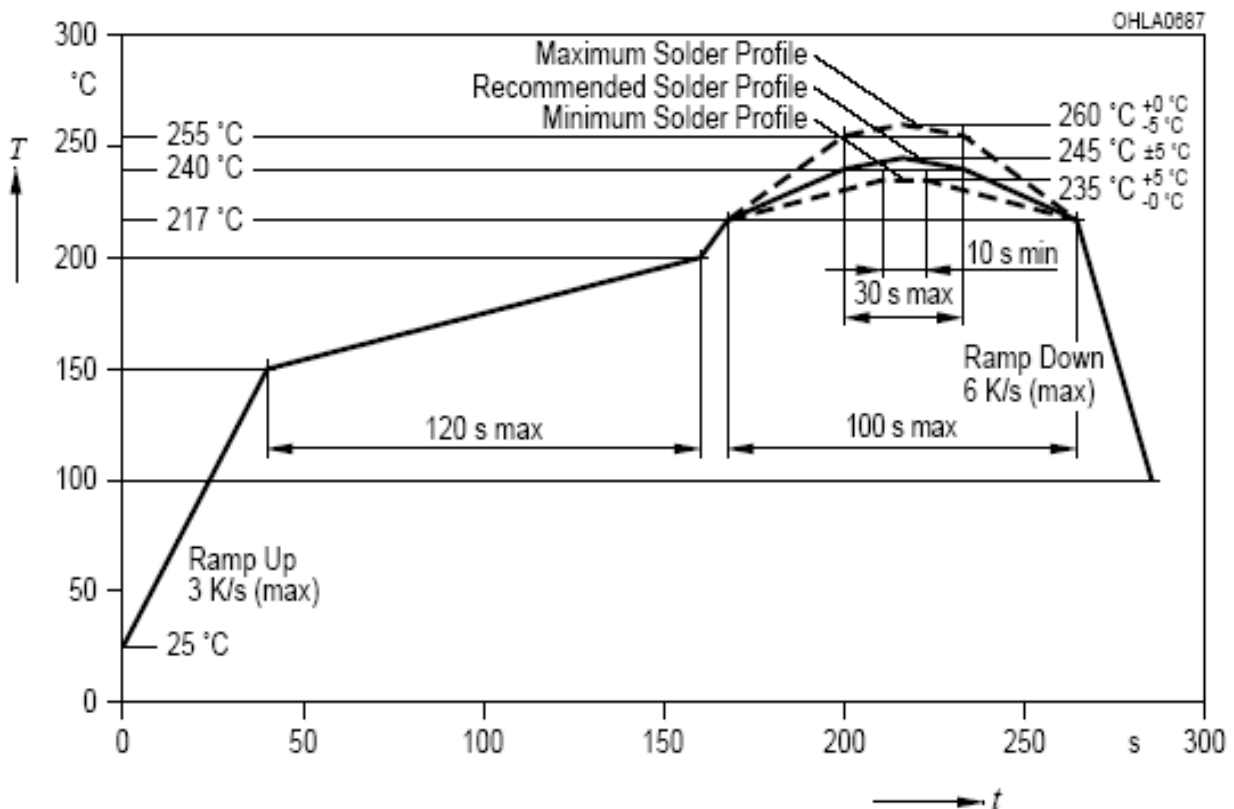

Property of Lite-On Only

Absolute Maximum Ratings at Ta=25°C

Parameter	Symbol	Values				Test Condition	Unit
			R	G	B		
Luminous flux ¹	Φ_v	Min	1.27	1.86	0.26	R: $I_F = 20\text{mA}$ G: $I_F = 20\text{mA}$ B: $I_F = 20\text{mA}$	lm
		Typ.					
		Max.	1.79	3.19	0.79		
Luminous Intensity	IV	Min	500	700	100	R: $I_F = 20\text{mA}$ G: $I_F = 20\text{mA}$ B: $I_F = 20\text{mA}$	mcd
		Typ.					
		Max.	700	1200	300		
Viewing Angle	$2\theta_{1/2}$	Typ.	120			$I_F = 20\text{mA}$	°
Dominant Wavelength ²	λ_d	Min	610	520	455	R: $I_F = 20\text{mA}$ G: $I_F = 20\text{mA}$ B: $I_F = 20\text{mA}$	nm
		Typ.					
		Max.	620	530	465		
Peak Wavelength	λ_p	Min				R: $I_F = 20\text{mA}$ G: $I_F = 20\text{mA}$ B: $I_F = 20\text{mA}$	nm
		Typ.	623	518	455		
		Max.					
Forward Voltage ³	V_F	Min	1.8	2.7	2.7	R: $I_F = 20\text{mA}$ G: $I_F = 20\text{mA}$ B: $I_F = 20\text{mA}$	V
		Typ.					
		Max.	2.4	3.3	3.3		
Luminous Flux	Φ_v	Typ.	1.57	2.66	0.49	$I_F = 20\text{mA}$	lm
Reverse Current	I_R	Max.	10			$V_R = 5\text{V}$	μA
Spectrum Radiation Bandwidth	$\Delta\lambda$	Typ.	20	33	22	$I_F = 20\text{mA}$	nm

Note :

1. Tolerance of Luminous Flux +/- 10%
2. Tolerance of Dominant Wavelength +/- 1nm
3. Tolerance of Forward Voltage +/- 0.1V
4. Caution in ESD:

Static Electricity and surge damages the LED. It is recommend to use a wrist band or anti-electrostatic glove when handling the LED. All devices, equipment and machinery must be properly grounded.

5. CAS140B is the test standard for the chromaticity coordinates Lm.

Property of Lite-On Only

Bin Code List

VF Spec. Table				
Forward Voltage (V) at I_F : R=20mA, G=20mA, B=20mA				
Rank				
Red	1.8 – 2.1		2.1 – 2.4	
Green	2.7 – 3.0	3.0 – 3.3	2.7 – 3.0	3.0 – 3.3
Blue				
2.7 – 3.0	V00	V10	W00	W10
3.0 – 3.3	V01	V11	W01	W11

Tolerance on each Forward Voltage bin is +/- 0.10volt.

Lm Spec. Table					
Luminous Flux (lm) at I_F : R=20mA, G=20mA, B=20mA					
Rank					
Red	1.27 – 1.79 (*500 – 700)				
Green	1.86 – 2.13 (*700 – 800)	2.13 – 2.39 (*800 – 900)	2.39 – 2.66 (*900 – 1000)	2.66 – 2.92 (*1000-1100)	2.92 – 3.19 (*1100-1200)
Blue					
0.26 – 0.52 (*100 – 200)	A21	A31	A41	A51	A61
0.52 – 0.79 (*200 – 300)	A22	A32	A42	A52	A62

Tolerance on each Luminous Flux bin is +/- 10%.

* Luminous intensity (mcd)

Bin Code List

λ_D Spec. Table		
Dominated Wavelength (nm) at I_F : R=20mA, G=20mA, B=20mA		
Rank		
Red	610 – 620	
Blue \ Green	520 – 525	525 – 530
455 – 460	M	N
460 – 465	P	R

Tolerance on each Dominated Wavelength bin is +/- 1nm.

Property of Lite-On Only

Typical Electrical / Optical Characteristics Curve

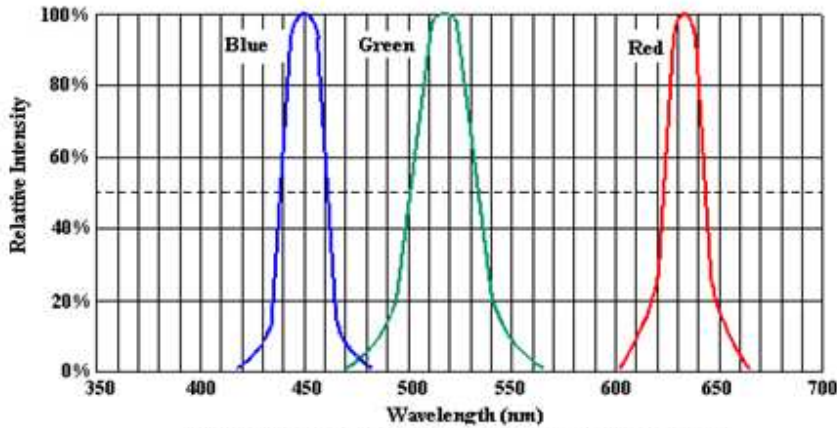
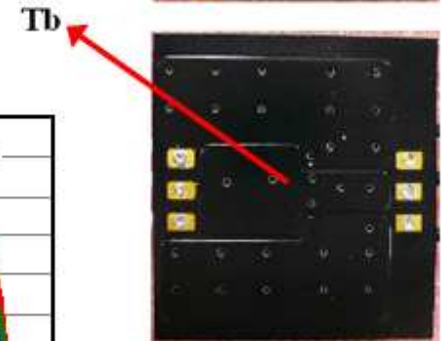
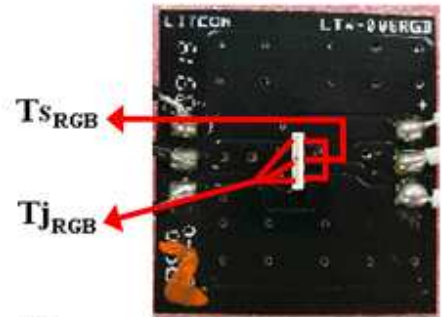

Fig.1 Relative Intensity vs Dominant Wavelength



Ts: Soldering Pin Temperature

Tj: Junction Temperature

Tb: Board Temperature

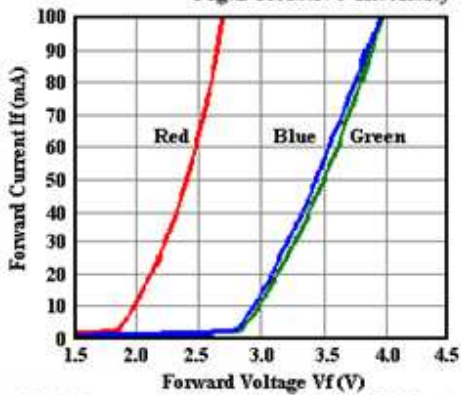

Fig.2 Forward Current vs Forward Voltage

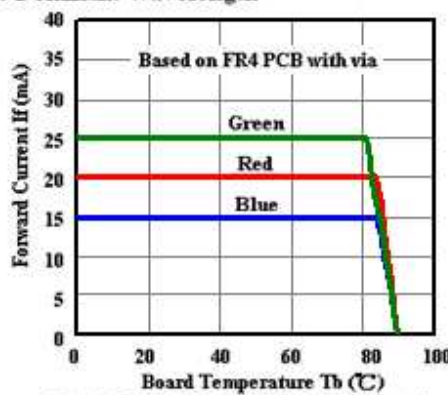

Fig.3 Forward Current Derating Curve

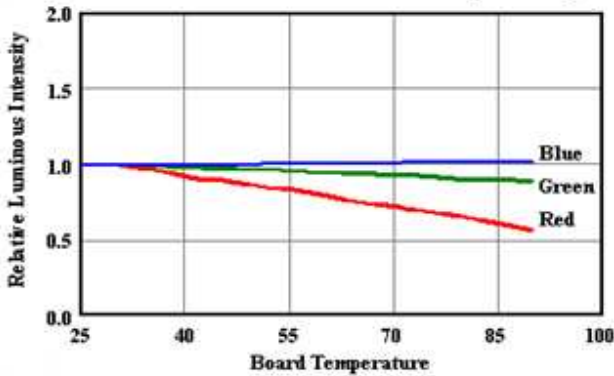

Fig.5 Luminous Intensity vs Board Temperature
(The characteristic curve are the same as R, G and B chip lighting up simultaneously)

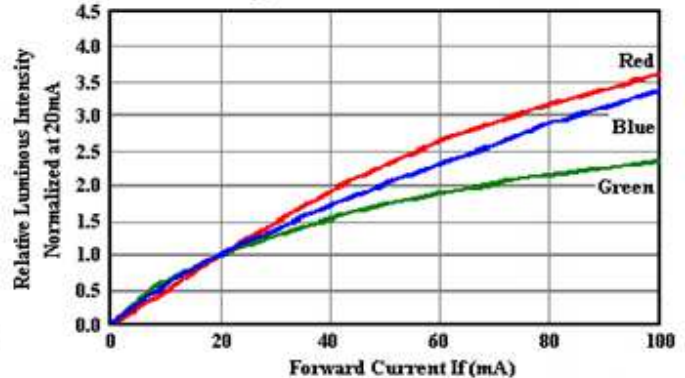

Fig.4 Relative Luminous Intensity vs Forward Current

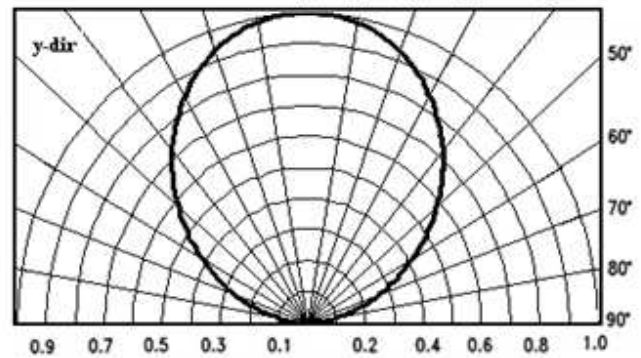
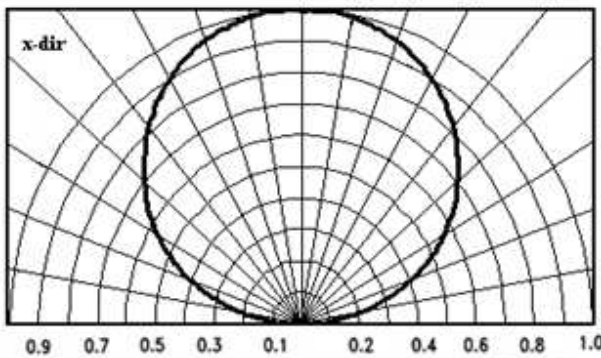

Fig.6 Spatial Distribution

Property of Lite-On Only

User Guide

Cleaning

Do not use unspecified chemical liquid to clean LED they could harm the package.
If cleaning is necessary, immerse the LED in ethyl alcohol or isopropyl alcohol at normal temperature for less one minute.

Recommend Printed Circuit Board Attachment Pad

Infrared / vapor phase
Reflow Soldering

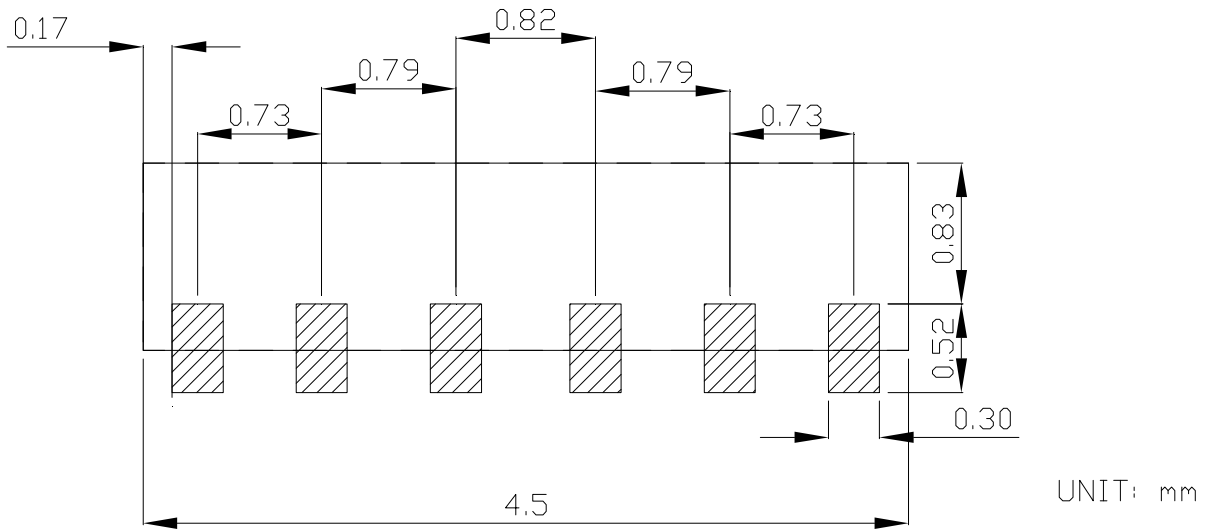

Package Dimensions of Tape

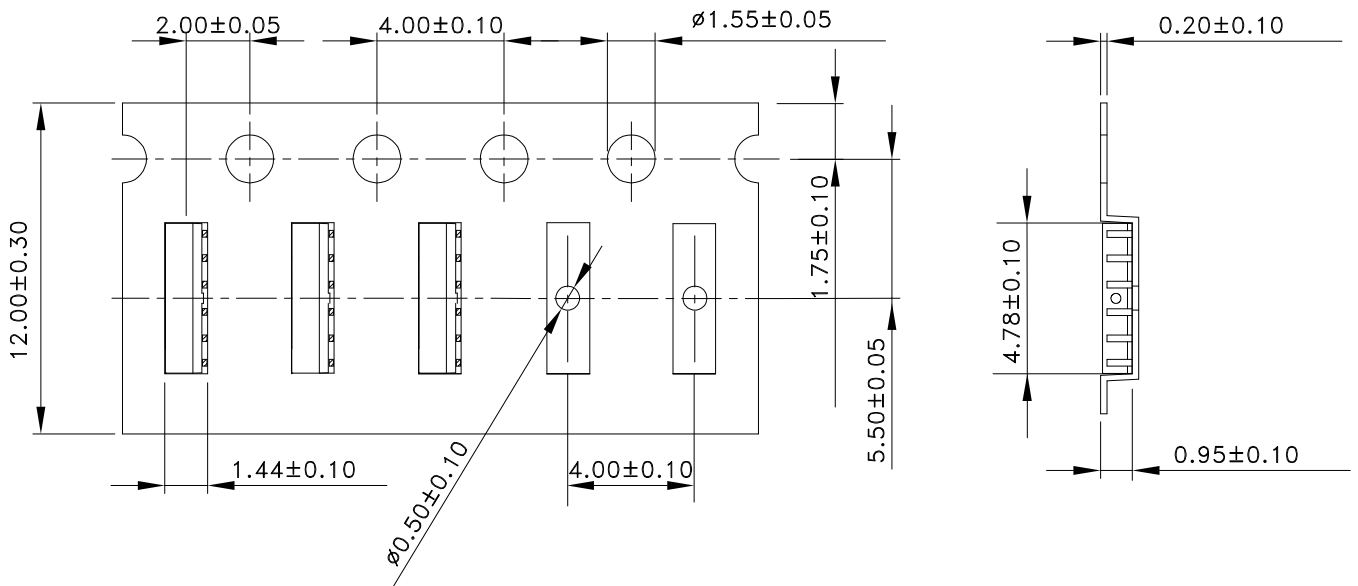

Note:

1.All dimensions are in millimeters.

Property of Lite-On Only

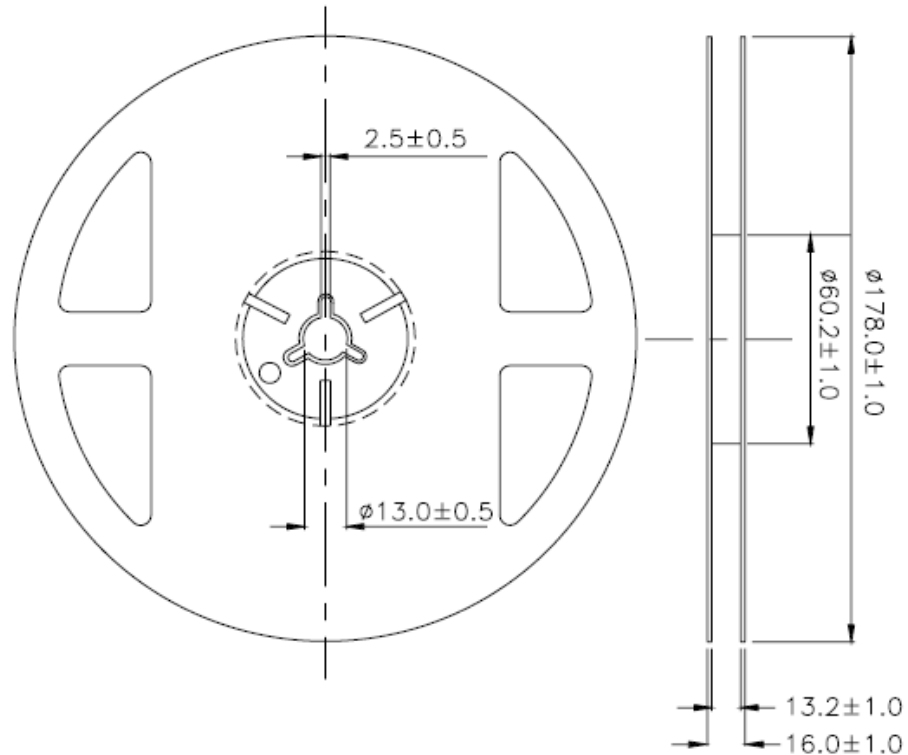
Package Dimensions of Reel

Note: Tolerances Unless Dimension $\pm 0.1\text{mm}$, Unit = mm

The material of reel was PC.

Notes:

1. Empty component pockets sealed with top cover tape.
2. 7 inch reel-2000 pieces per reel.
3. The maximum number of consecutive missing lamps is two.
4. In accordance with EIA-481-1-B specifications.
5. Vacate 20 cm (min) on start of packing tape and vacate 50 cm (min) on last of packing tape.

CAUTIONS

1. Application

The LEDs described here are intended to be used for ordinary electronic equipment (such as office equipment, communication equipment and household applications). Consult Liteon's Sales in advance for information on applications in which exceptional reliability is required, particularly when the failure or malfunction of the LEDs may directly jeopardize life or health (such as in aviation, transportation, traffic control equipment, medical and life support systems and safety devices).

2. Storage

This product is qualified as Moisture sensitive Level 3 per JEDEC J-STD-020 Precaution when handling this moisture sensitive product is important to ensure the reliability of the product.

The package is sealed:

The LEDs should be stored at 30°C or less and 90%RH or less. And the LEDs are limited to use within one year, while the LEDs is packed in moisture-proof package with the desiccants inside.

The package is opened:

The LEDs should be stored at 30°C or less and 60%RH or less. Moreover, the LEDs are limited to solder process within 168hrs. If the Humidity Indicator shows the pink color in 10% even higher or exceed the storage limiting time since opened, that we recommended to baking LEDs at 60°C at least 48hrs. To seal the remainder LEDs return to package, it's recommended to be with workable desiccants in original package.

3. Cleaning

Use alcohol-based cleaning solvents such as isopropyl alcohol to clean the LED if necessary.

4. Soldering

Recommended soldering conditions:

Reflow soldering		Soldering iron	
Pre-heat	120~150°C	Temperature	300°C Max.
Pre-heat time	120 sec. Max.	Soldering time	3 sec. Max.
Soldering Temp.	260°C Max.		(one time only)
Soldering time	30 sec. Max.		

5. Drive Method

An LED is a current-operated device. In order to ensure intensity uniformity on multiple LEDs connected in parallel in an application, it is recommended that a current limiting resistor be incorporated in the drive circuit, in series with each LED as shown in Circuit A below.

Circuit model A

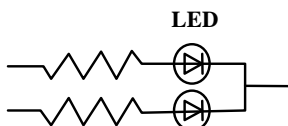

(A) Recommended circuit.

Circuit model B

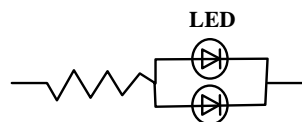

(B) The brightness of each LED might appear different due to the differences in the I-V characteristics of those LEDs.

Property of Lite-On Only

6. ESD (Electrostatic Discharge)

Static Electricity or power surge will damage the LED.

Suggestions to prevent ESD damage:

- Use of a conductive wrist band or anti-electrostatic glove when handling these LEDs.
- All devices, equipment, and machinery must be properly grounded.
- Work tables, storage racks, etc. should be properly grounded.
- Use ion blower to neutralize the static charge which might have built up on surface of the LED's plastic lens as a result of friction between LEDs during storage and handling.

ESD-damaged LEDs will exhibit abnormal characteristics such as high reverse leakage current, low forward Voltage, or "no light-up" at low currents.

To verify for ESD damage, check for "light up" and Vf of the suspect LEDs at low currents.

The Vf of "good" LEDs should be $>2.0V @ 0.1mA$ for InGaN product.

7.1 Reliability Test

Test Item	Test Condition	Reference Standard	Note	Number of Damaged
Solderability (Reflow Soldering)	Tsld=245±5°C, 3sec. (Lead Free Solder)	JEITA ED-4701 300 303	1 time Over 95%	0/50
Thermal Shock	-30°C ~ 85°C 30min. 30min.	JEITA ED-4701 300 307	100 cycles	0/50
Temperature Cycle	-40°C ~ 25°C ~ 100°C ~ 25°C 30min. 5min. 30min. 5min.	JEITA ED-4701 100 105	100 cycles	0/50
High Temperature Storage	Ta=100°C	JEITA ED-4701 200 201	1000 hrs.	0/50
Temperature Humidity Storage	Ta=60°C, RH=90%	JEITA ED-4701 100 103	1000 hrs.	0/50
Low Temperature Storage	Ta=-40°C	JEITA ED-4701 200 202	1000 hrs.	0/50
Steady State Operating Life Condition 1	Ta=25°C, IF=20mA		1000 hrs.	0/50
Steady State Operating Life Condition 2	Ta=25°C, IF=30mA		500 hrs.	0/50
Steady State Operating Life of High Temperature	Ta=85°C, IF=5mA		1000 hrs.	0/50
Steady State Operating Life of High Humidity Heat	60°C, RH=90%, IF=15mA		500 hrs.	0/50
Steady State Operating Life of low Temperature	Ta=-30°C, IF=20mA		1000 hrs.	0/50

7.2 Criteria for Judging the Damage

Item	Symbol	Test Conditions		Criteria for Judgment	
				Min.	Max.
Forward Voltage	VF	IF=20mA	-	-	U.S.L.*) × 1.1
Reverse Current	IR	VR=5V	-	-	U.S.L.*) × 2.0
Luminous Intensity	IV	IF=20mA	-	U.S.L.**) × 0.7	-

8. Others

The appearance and specifications of the product may be modified for improvement without prior notice.

9. Suggested Checking List

Training and Certification

1. Everyone working in a static-safe area is ESD-certified?
2. Training records kept and re-certification dates monitored?

Static-Safe Workstation & Work Areas

1. Static-safe workstation or work-areas have ESD signs?
2. All surfaces and objects at all static-safe workstation and within 1 ft measure less than 100V?
3. All ionizer activated, positioned towards the units?
4. Each work surface mats grounding is good?

Personnel Grounding

1. Every person (including visitors) handling ESD sensitive (ESDS) items wear wrist strap, heel strap or conductive shoes with conductive flooring?
2. If conductive footwear used, conductive flooring also present where operator stand or walk?
3. Garments, hairs or anything closer than 1 ft to ESD items measure less than 100V*?
4. Every wrist strap or heel strap/conductive shoes checked daily and result recorded for all DLs?
5. All wrist strap or heel strap checkers calibration up to date?

Note: *50V for Blue LED.

Device Handling

1. Every ESDS items identified by EIA-471 labels on item or packaging?
2. All ESDS items completely inside properly closed static-shielding containers when not at static-safe workstation?
3. No static charge generators (e.g. plastics) inside shielding containers with ESDS items?
4. All flexible conductive and dissipative package materials inspected before reuse or recycle?

Others

1. Audit result reported to entity ESD control coordinator?
2. Corrective action from previous audits completed?
3. Are audit records complete and on file?